

SILTSACK®

(U.S. Patent #5,575,925)

Catch Basin Sediment Capture Device

Keeping catch basins free of silt!

Now Available
in High Visibility
Yellow

Versatile

Available in 2 styles to meet your needs:

- High flow
- Regular flow

And It's Simple

- Remove drain grate
- Insert Siltsack
- Replace grate to hold Siltsack in position
- Siltsack traps silt
- Remove filled Siltsack easily
- Clean and reuse or simply discard and replace

Are you looking for a cost-effective, easy way to stop silt and sediment from entering catch basins on construction site? Siltsack is the simple and economical solution to prevent clogging of catch basins.

Siltsack is a sediment control device used to prevent silt and sediment from entering your drainage system by catching the silt and sediment while allowing water to pass through freely. Siltsack can be used as a primary or secondary sediment control device to prevent failure of your drainage system due to clogging. It must be maintained on a regular basis to function properly.

Siltsack is available in both high-flow or regular flow. A modified Siltsack is also available with a curb opening deflector attached to prevent sediment and debris from entering through curb openings. Constructed with properties shown on the Specifications page, Siltsack is a quality product designed to save time and money.



Routine inspection of a Siltsack's collected sediment level is important to prevent "ponding" around storm drains. We recommend the following maintenance schedule:

- Each Siltsack should be inspected after every major rain event.
- If there have been no major events, Siltsack should be inspected every 2-3 weeks.
- The yellow restraint cord should be visible at all times. If the cord is covered with sediment, the Siltsack should be emptied.

Typical Siltsack® Construction



installed Siltsack held in place by grate.

Type A

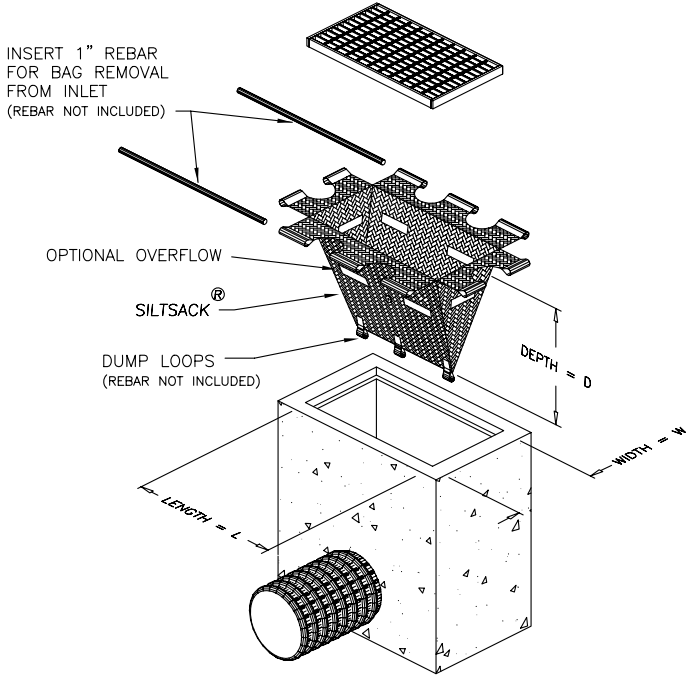

Type B

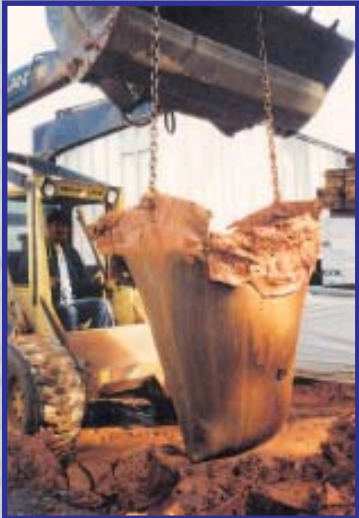
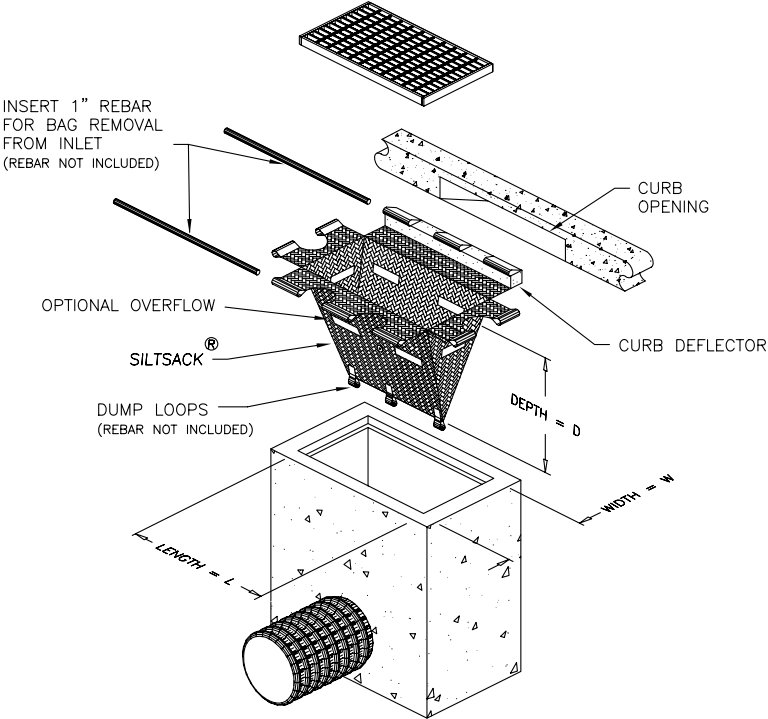

Sediment captured by Siltsack® can easily be removed from the site.

Siltsack® Specification

Control of Sediment Entering Catch Basins

(Storm Water Management)

1.0 Description

1.1 This work shall consist of furnishing, installing, maintaining, and removing Siltsack sediment control device as directed by the engineer or as shown on the site drawings. Siltsack sediment control device is manufactured by:

ACF Environmental, Inc.
 2831 Cardwell Road, Richmond, Virginia 23234
 Phone: 800-448-3636 • Fax: 804-743-7779
 www.acfenvironmental.com

2.0 Materials

2.1 Siltsack®

- 2.1.1** Siltsack shall be manufactured from a specially designed woven polypropylene geotextile and sewn by a double needle machine, using a high strength nylon thread.
- 2.1.2** Siltsack will be manufactured to fit the opening of the catch basin or drop inlet. Siltsack will have the following features: two dump straps attached at the bottom to facilitate the emptying of Siltsack; Siltsack shall have lifting loops as an integral part of the system to be used to lift Siltsack from the basin; Siltsack shall have a restraint cord approximately halfway up the sack to keep the sides away from the catch basin walls, this yellow cord is also a visual means of indicating when the sack should be emptied. Once the cord is covered with sediment, Siltsack should be emptied, cleaned and placed back into the basin.
- 2.1.3** Siltsack seams shall have a certified average wide width strength per ASTM D-4884 standards as follows:

Siltsack Style	Test Method	Test Method
Regular Flow	ASTM D-4884	165.0 lbs./in
Hi-Flow	ASTM D-4884	114.6 lbs./in

Siltsack Regular Flow

Property	Test Method	Units	Test Results
Grab Tensile	ASTM D-4632	lbs.	315x300
Grab Elongation	ASTM D-4632	%	15x15
Puncture	ASTM D-4833	lbs.	125
Mullen Burst	ASTM D-3786	P.S.I.	650
Trapezoid Tear	ASTM D-4533	lbs.	120x150
UV Resistance	ASTM D-4355	%	90
Apparent Opening	ASTM D-4751	US Sieve	40
Flow Rate	ASTM D-4491	Gal/Min/Ft ²	40
Permittivity	ASTM D-4491	sec ⁻¹	0.55

or SILTSACK® High Flow

Property	Specification	Units	Test Results
Material	Polypropylene		
Weight	5.6 oz/sq yd		
Color	Black		
Grab Tensile Strength	390lbs (530N)	lbs.	255x275
Grab Elongation (Max %)	30%	%	20x15
Traezoid Tear	120 lbs (250N) Min	lbs.	40x50
Puncture	140 lbs (250N) Min	lbs.	135
Mullen Burst	600 psi	P.S.I.	420
Coefficient of Permeability	0.04 in/sec		
Permittivity	0.3 gal/min/sq ft	sec ⁻¹	1.5
Water Flow Rate	152 gal/min/sq ft	gal/min/ft ²	200
AOS	0.212mm	US Seive	40
UV Resistance Strength	90%		
Fabric Width	72"		

All properties are Minimum Average Roll Values (MARV)

3.0 Construction Sequence

3.1 General

- 3.1.1** To install Siltsack in the catch basin, remove the grate and place the sack in the opening. Hold approximately six inches of the sack outside the frame. This is the area of the lifting straps. Replace the grate to hold the sack in place.
- 3.1.2** When the restraint cord is no longer visible, Siltsack is full and should be emptied.
- 3.1.3** To remove Siltsack, take two pieces of 1" diameter rebar and place through the lifting loops on each side of the sack to facilitate the lifting of Siltsack.
- 3.1.4** To empty Siltsack, place unit where the contents will be collected. Place the rebar through the lift straps (connected to the bottom of the sack) and lift. This will lift Siltsack from the bottom and empty the contents. Clean out and rinse. Return Siltsack to its original shape and place back in the basin.
- 3.1.5** Siltsack is reusable. Once the construction cycle is complete, remove Siltsack from the basin and clean. Siltsack should be stored out of sunlight until next use.

4.0 Basis of Payment

- 4.1** Payment for all Siltsacks used during construction is to be included in the bid price for the overall erosion and sediment control plan unless unit price is requested. Maintenance of Siltsack also to be included in this price.

**Silt sack is covered by U.S. Patent No. 5,575,925.*

Installation and Maintenance



Remove grate from catch basin.



Slide Siltsack® over one side of grate.



Slide Siltsack® over opposite side of grate.



Replace Siltsack® and grate inlet into recess.



Installed Siltsack®.



To remove Siltsack®, clean area around grate and slide rebar through Siltsack® pockets.



Slowly remove Siltsack® from inlet.



Removed Siltsack® is now ready for cleanout.



To clean Siltsack® attach rebar through empty loops at bottom and lift to empty.

ACF Environmental “Complete Source for Stormwater Solutions”

Distributed by:



1930 Aldine Western Rd
Houston, Texas 77038
832.456.1000
www.ecosvs.com