

GutterGator Specification:

For Curb Gutter Storm Drains

1.0 Description

1.1 This work shall consist of furnishing, placing, maintaining and removing the GutterGator sediment control device as directed by the engineer and as shown on the contract drawings. The GutterGator sediment control system manufactured by:

*ACF Environmental, Inc.
2831 Cardwell Road
Richmond, Virginia 23234
Phone: 800-448-3636 • Fax: 804-743-7779
www.acfenvironmental.com*

2.0 Materials

2.1 GUTTERGATOR

2.1.1 The GutterGator will be manufactured to 4' molds in 4', 6', 8', 10', 12', 14' and 16' lengths and a minimum of twenty-four (24) inches longer than the curb inlet opening. This will allow for sufficient length to cover the inlet with twelve (12) inches beyond the inlet on both ends.

3.0 Construction Sequence

3.1 General

3.1.1 Install the GutterGator in front of the curb inlet opening. Drop 7lb weight sock into inlet opening, secure tie pouch straps, if applicable. Each end of the GutterGator should overlap the curb inlet approximately 12".

3.1.2 The GutterGator should be cleaned if a visual inspection shows sediment and debris build up around the GutterGator.

3.1.3 To remove the GutterGator, lift out of curb opening with provided lift strap.

3.1.4 Clean as needed. Store out of direct sunlight.

3.1.5 Ponding is likely if sediment is not removed regularly. Inspection of GutterGator should be on a regular basis and immediately after wet weather events.

GutterGator Installation and Maintenance:

- Place GutterGator on the ground near curb inlet.
- Place unit in curb inlet so weighted flap hangs down in curb inlet holding GutterGator firmly in place.
- Center unit so 1' of GutterGator extends beyond each end of curb inlet.
- Secure tie back straps with sod pin or stake if applicable.
- Inspection after each wet weather event is recommended.
- Remove all sediment and debris from surface after each wet weather event.
- Remove GutterGator, clean out and replace.

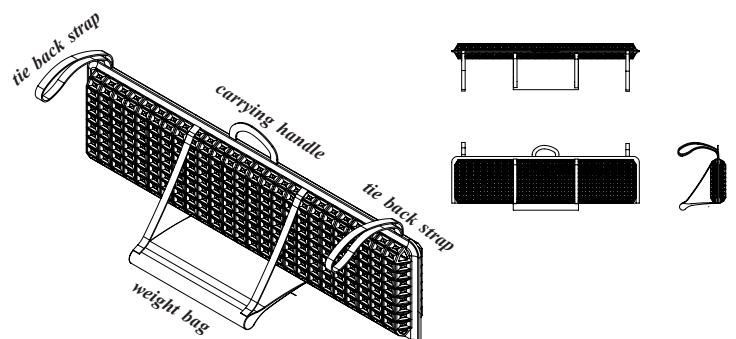

ACF Environmental

“Complete Source for Storm Water Solutions”



(800) 644-9223
www.thebmpstore.com

Distributed by:



2831 Cardwell Road
Richmond, Virginia 23234
(800) 448-3636 • FAX (804) 743-7779
www.acfenvironmental.com



Sediment Containment



GutterGator™ Curb Inlet Filter

GutterGator™ Advantages

- *Unique design - ships in 4' box*
- *Easy to transport and install*
- *Easy to assemble*
- *Keeps sediment, trash, and debris out of storm sewers*
- *Easy to clean and reuse*
- *Weight pocket holds unit in place*
- *Unique multi-dimensional outer filter with rigid inner frame allows high flow rates*
- *Low profile to curb helps prevent damage from vehicles*
- *Tie back straps for additional support*
- *Custom sizes available*

GutterGator™

The GutterGator™ is the latest inlet filter technology available from ACF Environmental.

Designed for curb inlets, GutterGator™ is designed for high flow volumes while maintaining maximum sediment retention.

With its unique multi-dimensional outer filter combined with a rigid inner frame, the GutterGator™ maintains a low profile to the curb preventing damage.

Save time and money! GutterGator™ installs in seconds, removes in minutes and is reusable. Stop sediment in its tracks with GutterGator!

Call ACF Environmental for more information.

