

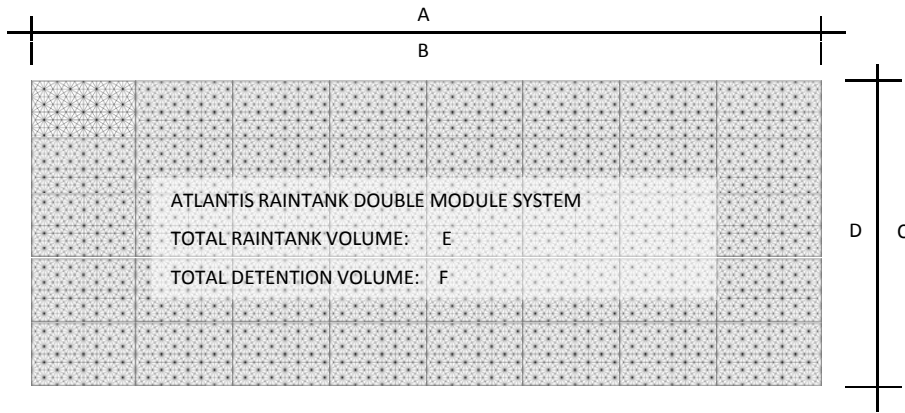

FOR ADDITIONAL INFORMATION CONTACT CONSTRUCTION ECOSERVICES  
 P: 832.456.1000 • WWW.ECOSVS.COM • F: 832.456.1010

ATLANTIS RAINTANK UNDERGROUND DETENTION SYSTEM		
A	RAINTANK LENGTH	
B	# TANK LONG	
C	RAINTANK WIDTH	
D	# TANKS WIDE	
E	RAINTANK VOLUME	
F	WATER VOLUME	
G	INLET FLOWLINE	
H	OUTLET FLOWLINE	
I	TOP OF PAVING (Lowest)	

**PLAN VIEW**



**PROFILE VIEW**

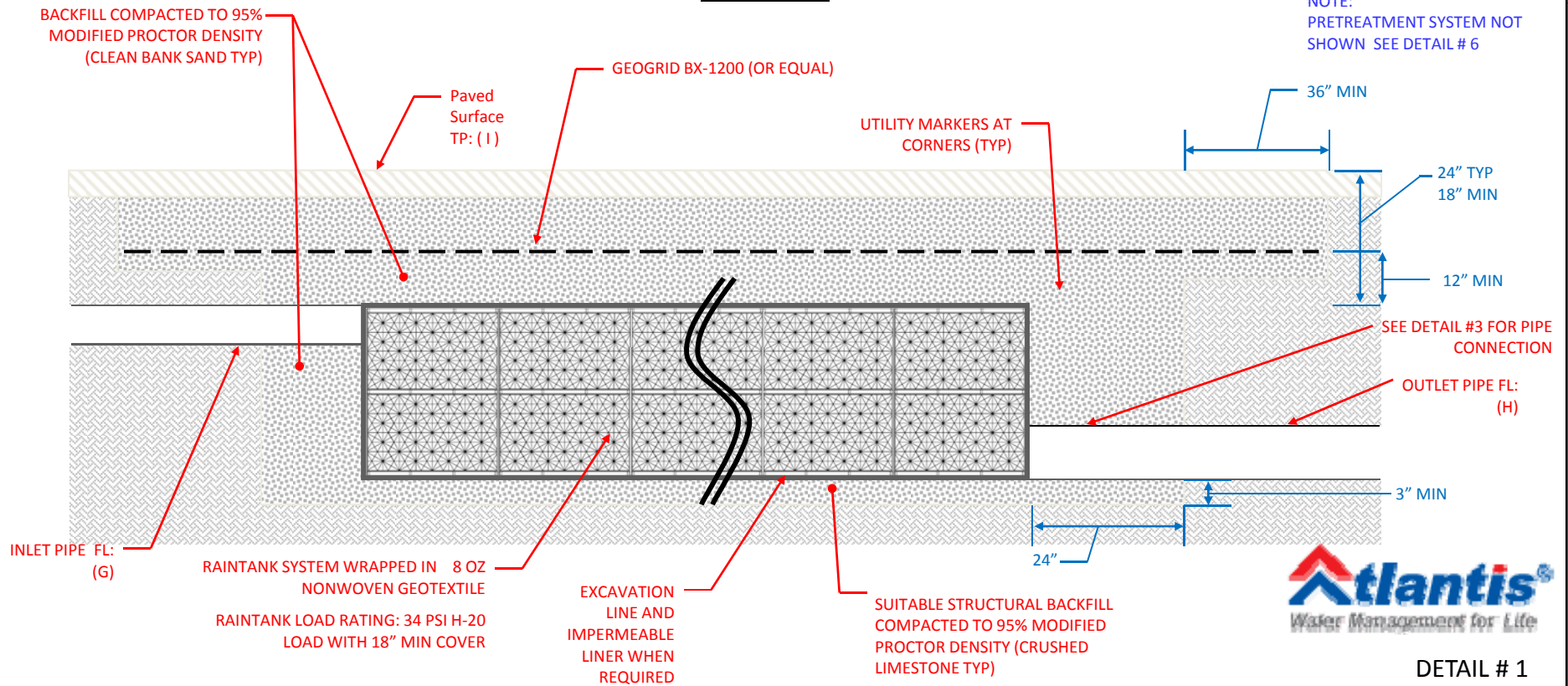

DETAIL # 1

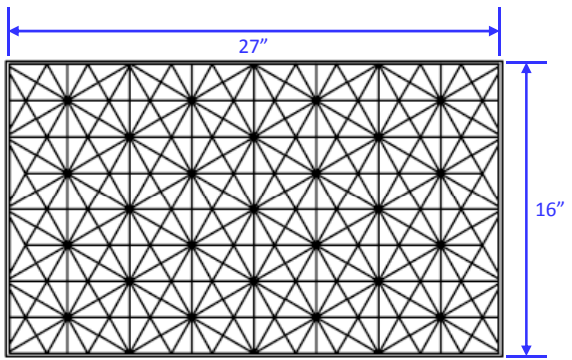

PLAN VIEW

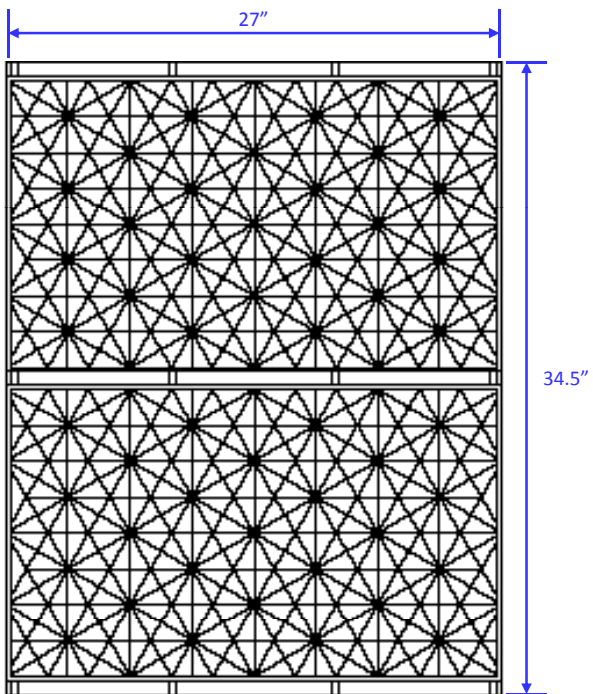

SIDE VIEW

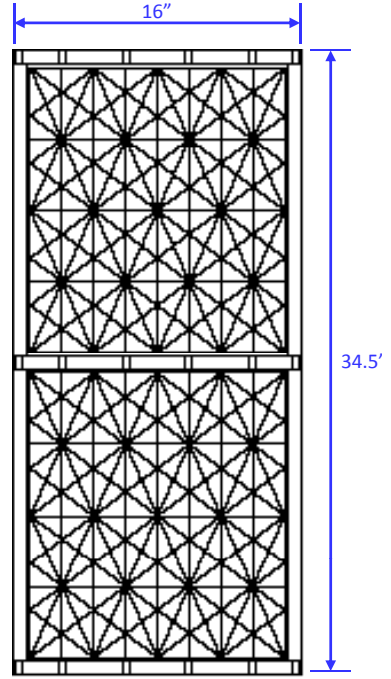

FRONT VIEW

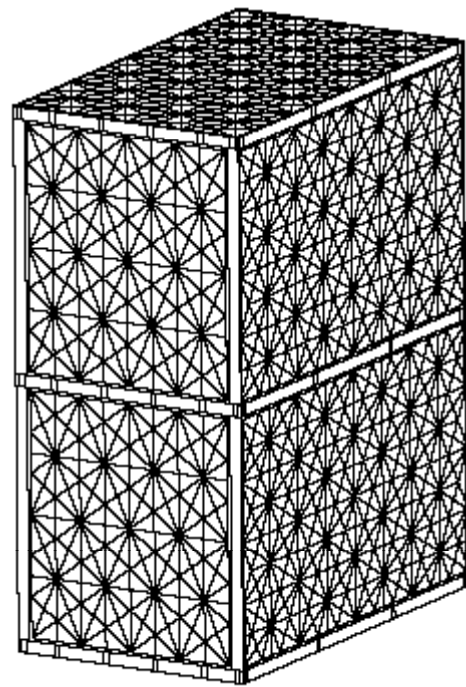

ISOMETRIC VIEW

DIMENSIONS SHOWN ARE NOMINAL,  
REFER TO MODULE DATA

**MODULE DATA**

<b>GEOMETRY:</b>	LENGTH = 26.97IN. (685MM)	<b>LOAD RATING:</b>	34 PSI, (MODULE ONLY)	
	WIDTH = 16.06 IN (408MM)		H-20 (COVER PER SPEC.)	
<b>MATERIAL:</b>	HEIGHT = 34.65 IN. (880MM)	<b>MATERIAL:</b>	85% RECYCLED	
	STORAGE VOLUME = 8.69 CF (245 L)		POLYPROPYLENE	
	VOID INTERNAL VOLUME: 95%			
	VOID SURFACE AREA: 90%			

**RAINTANK DOUBLE MODULE**



FOR ADDITIONAL INFORMATION CONTACT CONSTRUCTION ECOSERVICES  
P: 832.456.1000 • WWW.ECOSYS.COM • F: 832.456.1010



**PIPE CONNECTION**

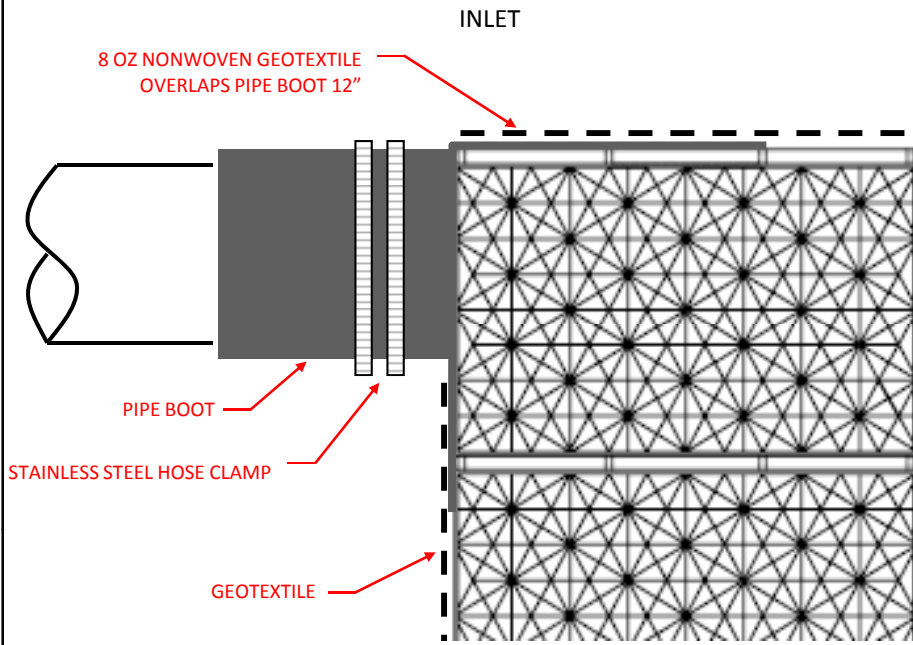

**PIPE BOOT**

**FRONT VIEW**

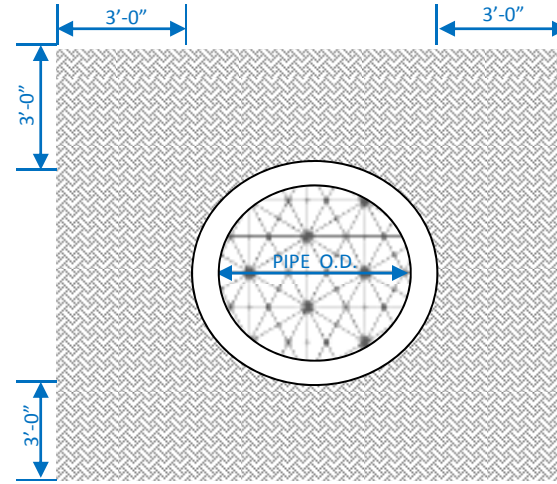

**OUTLET**

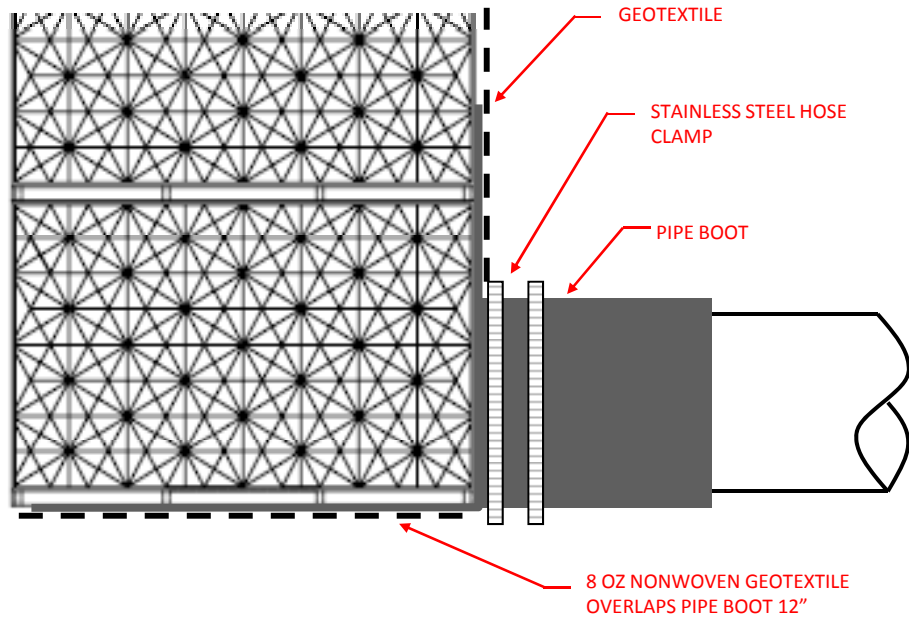

**SIDE VIEW**

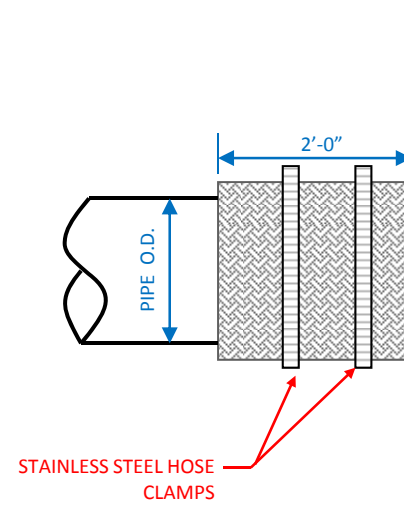

**PIPE CONNECTION TO RAIN TANK SYSTEM**

**MAINTENANCE PORT**

THIS PORT IS USED TO PUMP WATER INTO THE SYSTEM AND RESUSPEND ACCUMULATED SEDIMENT SO THAT IT MAY BE PUMPED OUT. MINIMUM REQUIRED MAINTENANCE INCLUDES A QUARTERLY INSPECTION FOR THE FIRST YEAR OF OPERATION AND A YEARLY INSPECTION THEREAFTER. FLUSH AS NEEDED

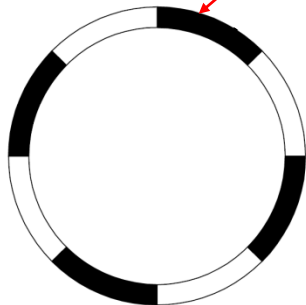
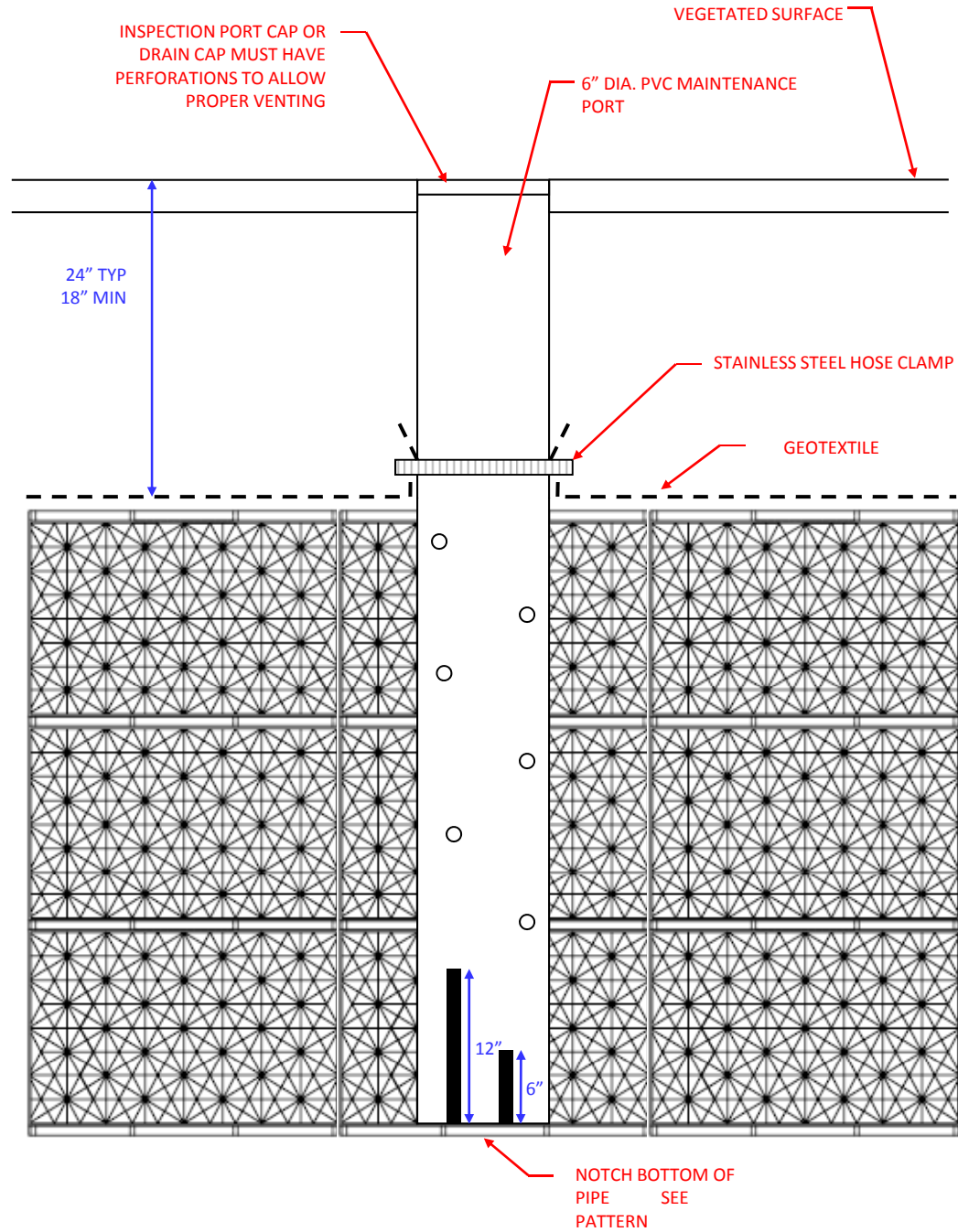

PIPE NOTCHING PATTERN

# INSPECTION / VENT PORT



FOR ADDITIONAL INFORMATION CONTACT CONSTRUCTION ECOSERVICES

P: 832.456.1000 • WWW.ECOSYS.COM • F: 832.456.1010



DETAIL # 4

PLAN VIEW

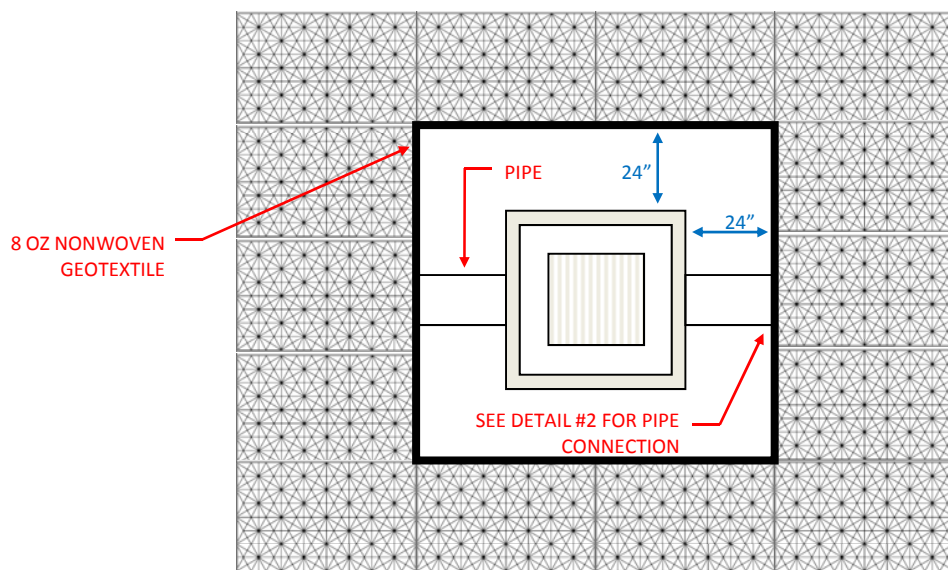

PROFILE VIEW

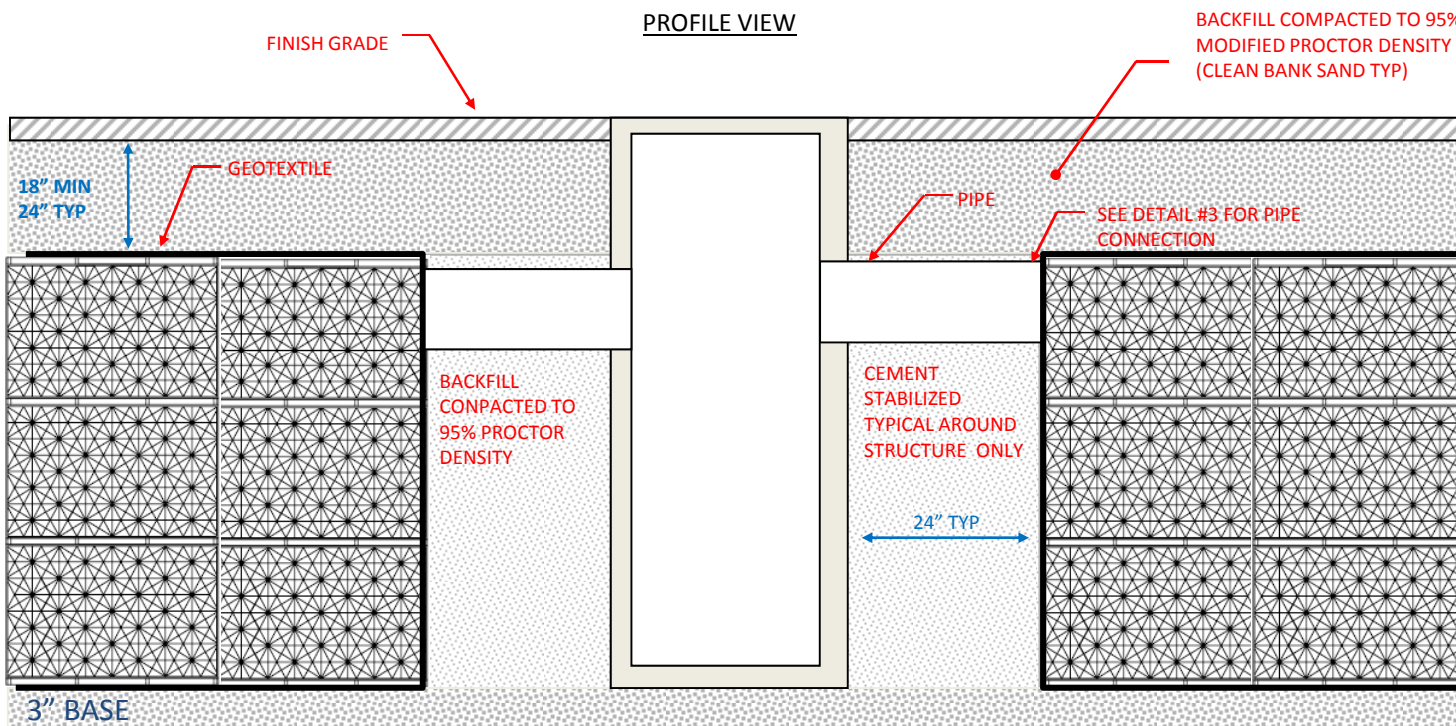

# CATCH BASIN IN MIDDLE OF RAIN TANK SYSTEM

**GRATE INLET SKIMMER BASKET**

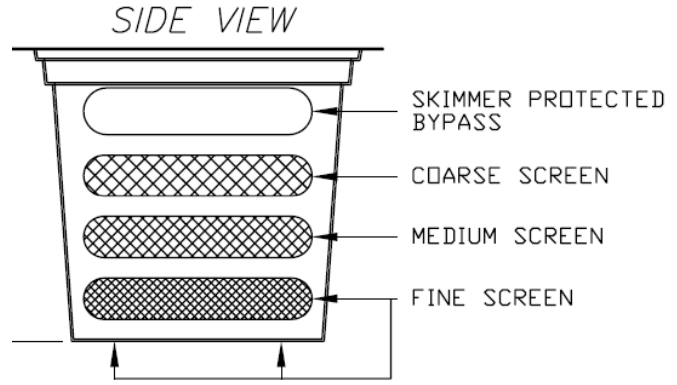
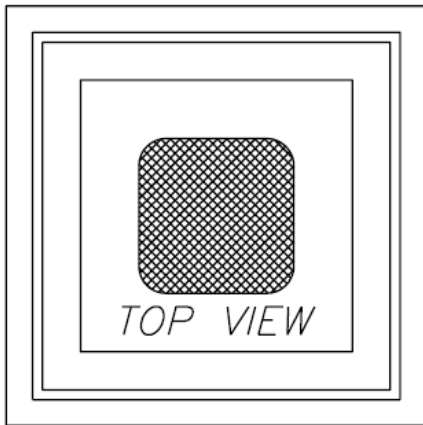
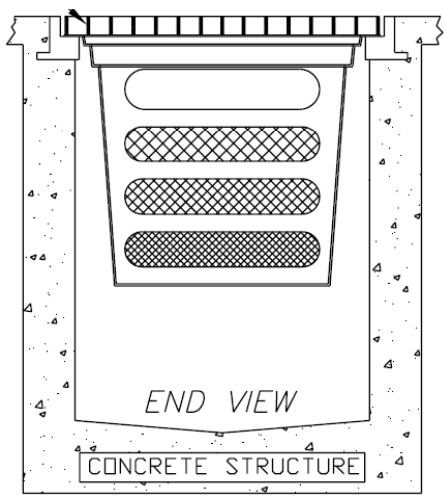

SEE SPECIFICATIONS FOR  
MAINTENANCE AND INSTALATION  
INSTRUCTIONS

**CURB INLET SKIMMER BASKET**

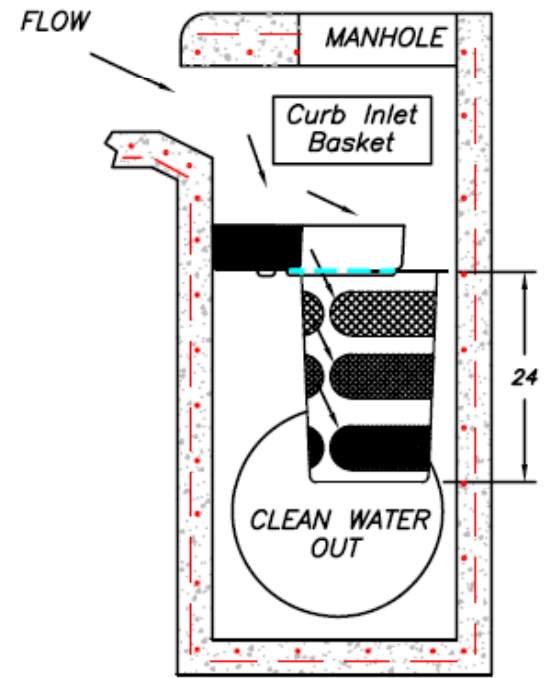
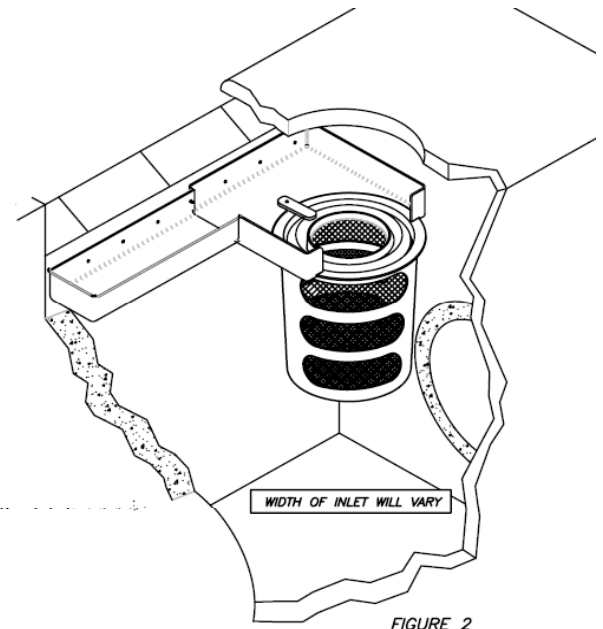

**SUNTREE TECHNOLOGIES INLET TREATMENT SYSTEM**



DETAIL # 6A

FOR ADDITIONAL INFORMATION CONTACT CONSTRUCTION ECOSERVICES  
P: 832.456.1000 • WWW.ECOSYS.COM • F: 832.456.1010



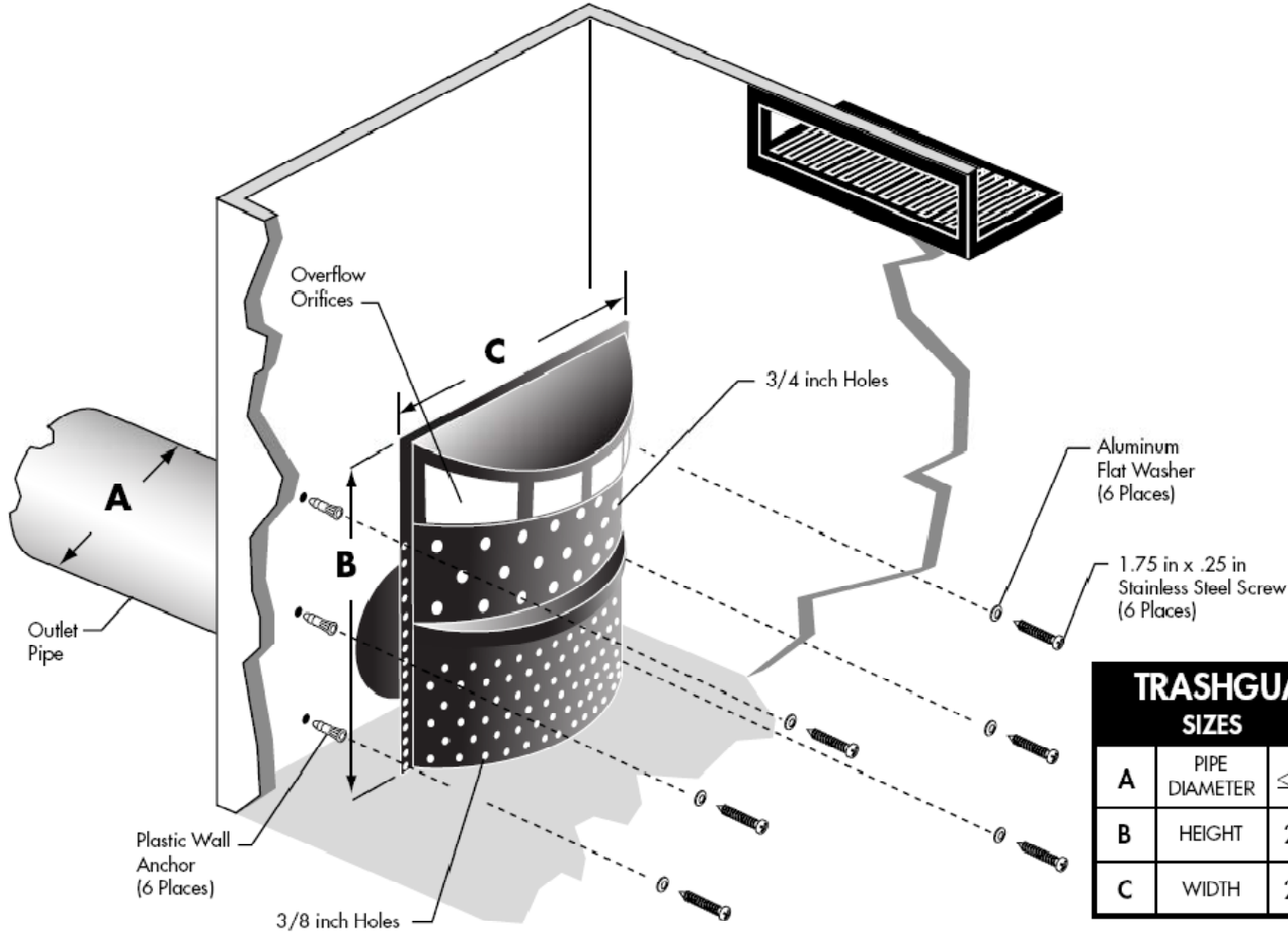

TRASHGUARD DETAILS				
SIZES		23"	28"	34"
A	PIPE DIAMETER	≤ 15"	≤ 18"	≤ 24"
B	HEIGHT	24"	30"	36"
C	WIDTH	23"	28"	34"

# TRASH GUARD INLET TREATMENT SYSTEM

FOR ADDITIONAL INFORMATION CONTACT CONSTRUCTION ECOSERVICES  
 P: 832.456.1000 • WWW.ECOSYS.COM • F: 832.456.1010

